

Uni-Pallet®

NP4048E



Uni-Pallet is RPP's solution to distributor's needs: A lightweight, reusable, nine-leg, 4-way entry, twin sheet pallet. Manufactured from BA50-100, high-molecular weight, high-density polyethylene co-polymer for maximum product performance.

This (9) leg nestable pallet is manufactured by twin sheet thermoforming and is rated at 1500# dynamic load.

NP 4048E nestable pallets are perfect for:

- Export
- Parts Distribution
- Clean Room Applications
- Laboratories
- Electronics

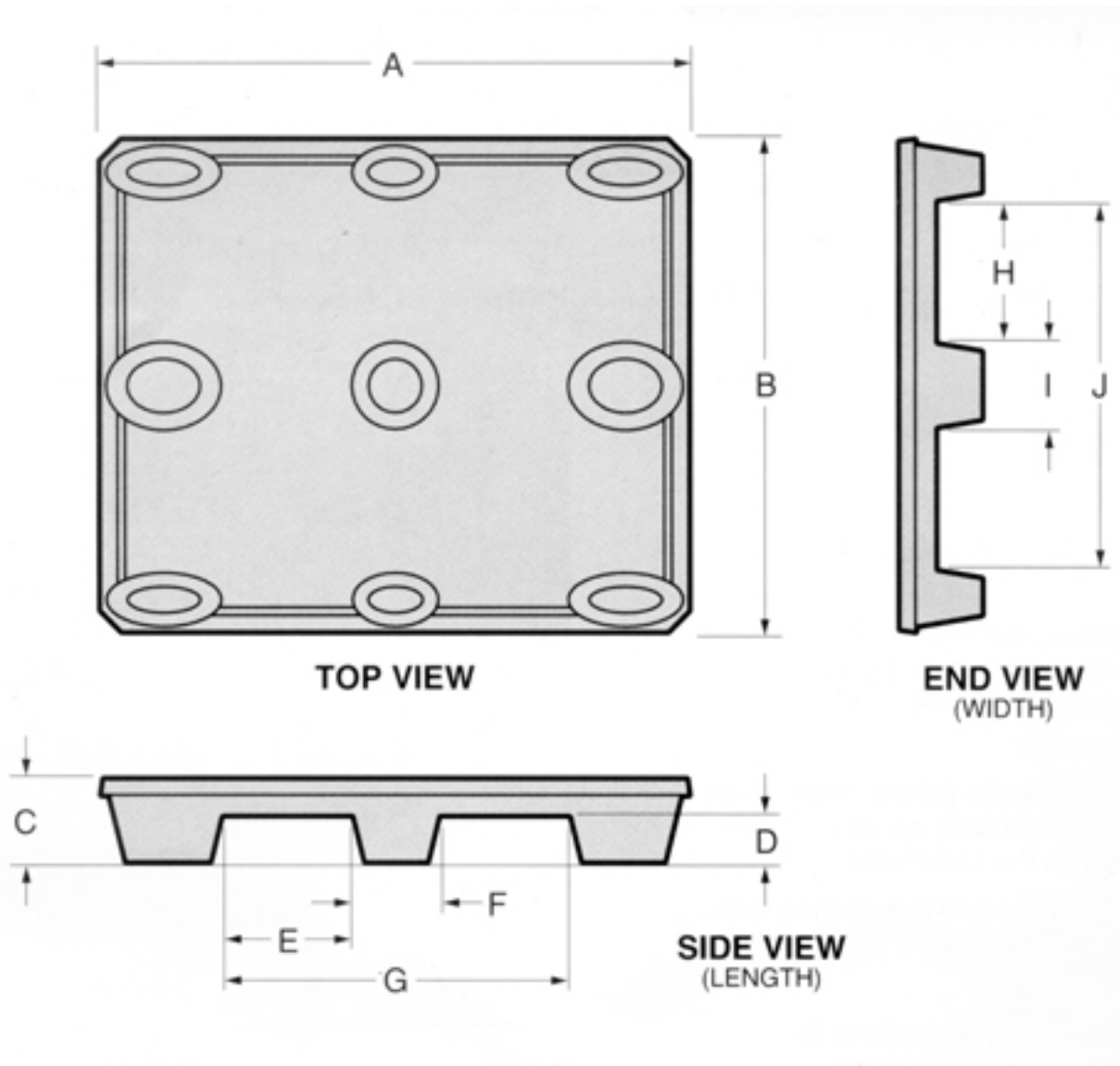

Pallet Dimensions

A Overall Length	48"	F Center Leg/Length	5.9"
B Overall Width	40"	G Overall Fork Opening/Length	29.9"
C Overall Height	6.5"	H Fork Opening/Width	12.05"
D Fork Opening/Height	4"	I Center Leg/Width	5.9"
E Fork Opening/Length	12"	J Overall Fork Opening/Width	30"

Warehousing & Shipping Information

Pallets nest on 2.5" centers
 Truckload Quantity: 1200 Pallets (53' x 98' x 110') 30 Stacks of 40 Pallets
 Truckload Quantity: 1120 Pallets (48' x 98' x 110') 28 Stacks of 40 Pallets